

Left Spindle

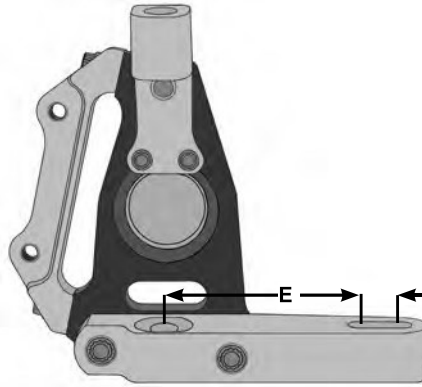
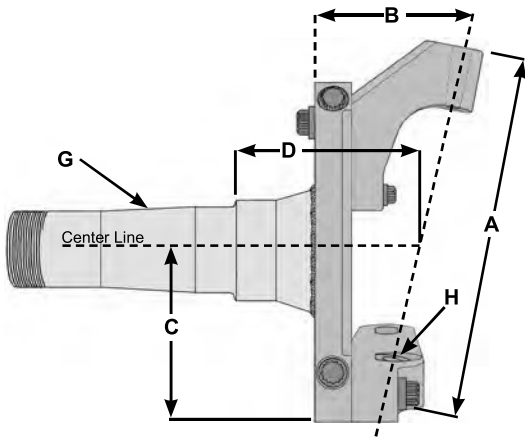

- A= Spindle Height _____
- B= Inclination _____
- C= Pin Height _____
- D= Track Width _____
- E= Steering Arm Length _____
- F= Slot Length _____
- F= Optional Hole Size _____
- G= Type Of Snout _____
- H= Lower Ball Joint 6141 or 727

Right Spindle

- A= Spindle Height _____
- B= Inclination _____
- C= Pin Height _____
- D= Track Width _____
- E= Steering Arm Length _____
- E= Hole Size _____
- F= Optional Slot Size _____
- F= Slot Length _____
- G= Type Of Snout _____
- H= Lower Ball Joint 6141 or 727

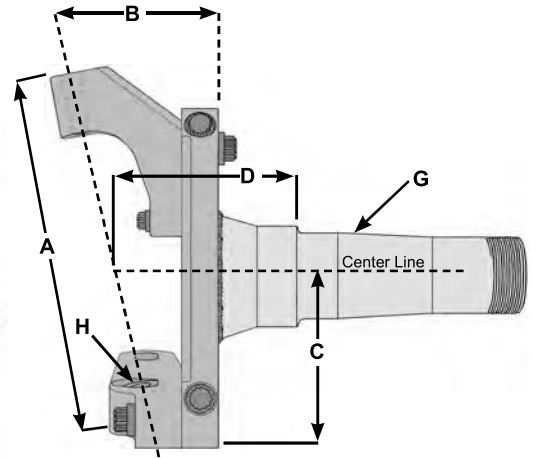
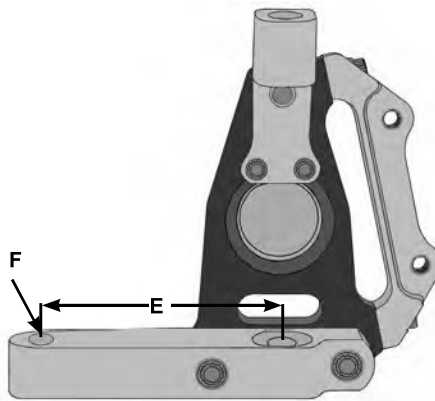

Steering Arm Options

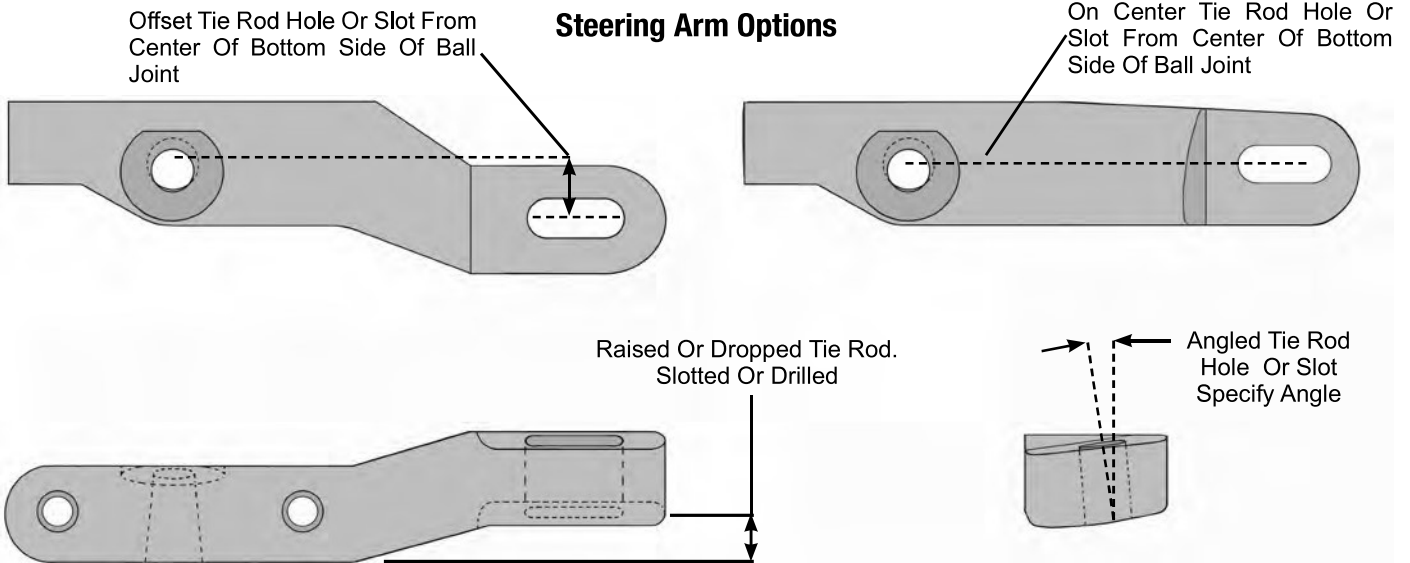

NOTES: _____

Signed: _____ Date: _____

NOTE: Coleman Machine is not responsible for mistake in measurements that are provided by the customer. Once any custom part is made to the customer sizes as provided there are no returns, refunds or exchanges. **DOUBLE CHECK ALL YOUR SIZES.**