

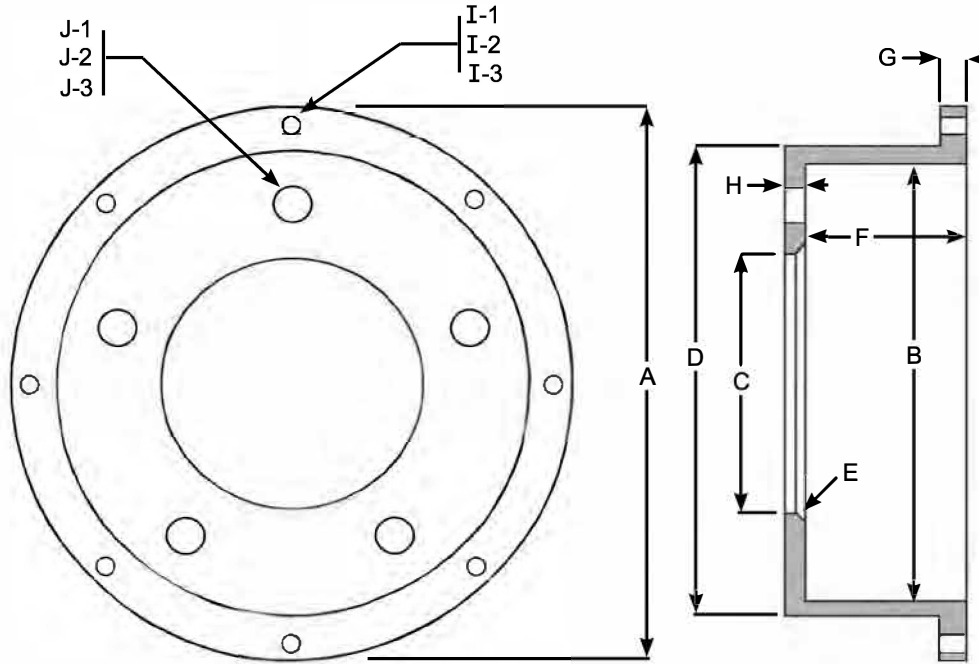

- CUSTOM ROTOR MOUNTING HATS -

Custom Solid Mount Hat Sheet



No Metric Sizes Please

- "A" (Outside Dia.) _____
- "B" (Inside Dia.) _____
- "C" (Center Bore) _____
- "D" (Face Diameter) _____
- "E" (Chamfer size) _____
- "F" (Offset) _____
- "G" (Flange Thickness) _____
- "H" (Face Thickness) _____
- "I-1" (No. Of Holes) _____
- "I-2" (Bolt Circle) _____
- "I-3" (Size Of Holes) _____
- "J-1" (No. Of Holes) _____
- "J-2" (Bolt Circle) _____
- "J-3" (Size Of Holes) _____

Material: Aluminum / Steel

Finish: Plain / Anodized

Approved By: _____ Date: _____

Custom Bobbin Style Floating Hat Sheet

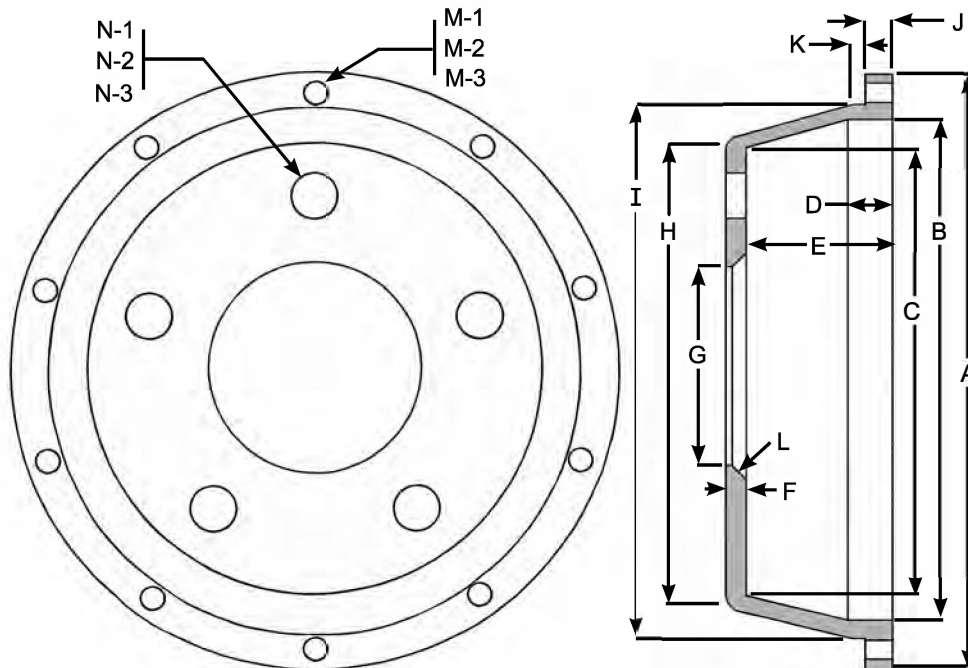

No Metric Sizes Please

- "A" (Outside Dia.) _____
- "B" (Inside Dia.) _____
- "C" (Inside Dia.) _____
- "D" (Depth) _____
- "E" (Offset) _____
- "F" (Face Thickness) _____
- "G" (Center Bore) _____
- "H" (Face Dia.) _____
- "I" (Step Dia.) _____
- "J" (Flange Thickness) _____
- "K" (Step Length) _____
- "L" (Chamfer Size) _____
- "M-1" (No. Of Holes) _____
- "M-2" (Bolt Circle) _____
- "M-3" (Hole Size) _____
- "N-1" (No. Of Holes) _____
- "N-2" (Bolt Circle) _____
- "N-3" (Hole Size) _____

Material: Aluminum / Steel

Finish: Plain / Anodized

Approved By: _____ Date: _____

All custom rotor hats are machined to customer specifications. When measuring be as accurate as possible with your dimensions and provide tolerances for each dimension. If you cannot supply Coleman with accurate sizes you may send a sample, we will draw a blueprint from the sample and send the print for approval. We will not make any custom hats with sizes provided over the phone. All custom hat sheets must be signed and dated by the person supplying the sizes. Coleman Machine, Inc. is not responsible for any failure of custom hats due to improper fit, improper sizes, improper tolerances or any problems encountered with the size, design or fit of the finished part machined to the customer specifications. No return on any custom part or parts that have been altered in any way.